



# ME-CB

## Conduit Box



## Installation Guide

## Introduction

### Introduction

The ME-CB Conduit Box fits on the front side of the Magnum ME, MS and RD Series inverters and accommodates installations where the electrical code requires the AC and/or DC wiring to be enclosed/protected by conduit.

This enclosure provides knockouts for use with 1/2", 3/4", 1" and 2" trade size conduit and adds just over 5" (13 cm) to the length of the inverter.

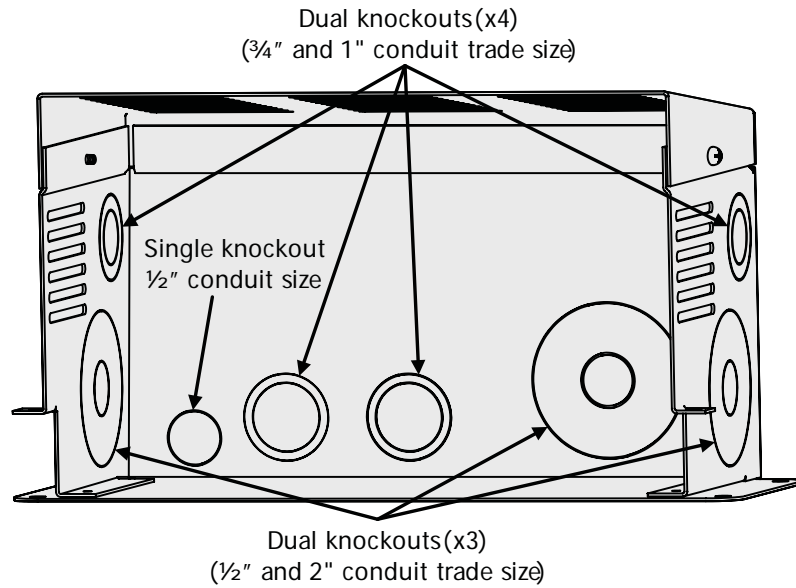

**Figure 1, ME-CB Knockout Sizes**

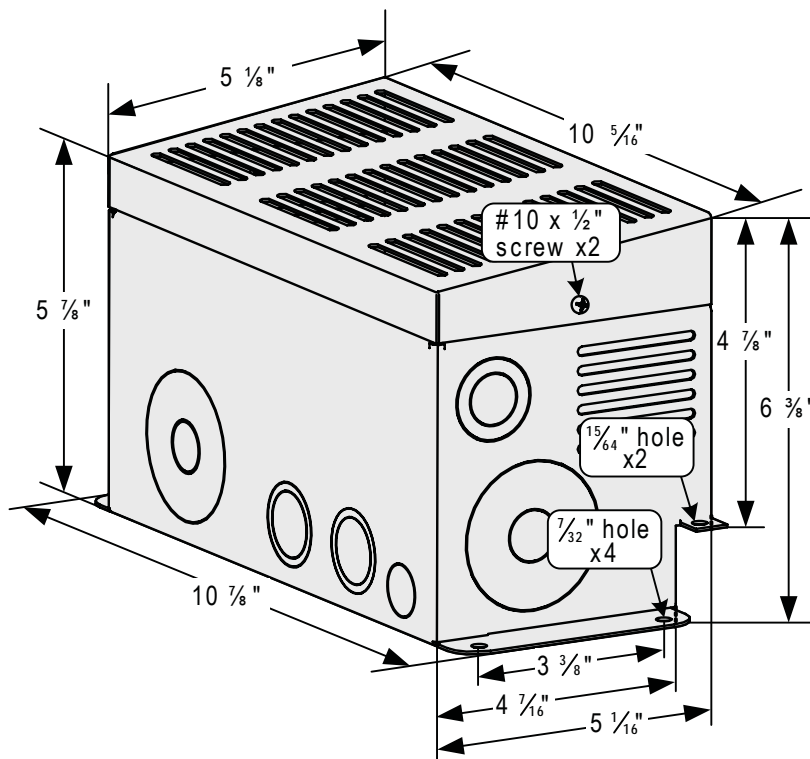

**Figure 2, ME-CB Dimensions**

## Installation



**WARNING:** The inverter uses power from both AC and DC sources. Before beginning the installation, ensure all AC power (utility/generator) and all negative and positive battery cables are safely disconnected from the inverter.

Refer to figure 3 for the following steps:

1. Remove the cover of the conduit box by removing the two #10 - 1/2" Phillips screws attaching the cover to the bottom.
2. Determine the AC and DC wiring thru the conduit box and remove the appropriate knockouts and attach corresponding strain reliefs.
3. On the inverter, remove the two #25 Torx screws that hold the inverter cover located on the inverter's front side.
4. Align the conduit box with the front side of the inverter; placing the holding tab located on the conduit box bottom over the screw openings from the #25 Torx screws removed in step 3.
5. Attach the conduit box to the inverter using the two #25 Torx screws that were removed from the inverter cover in step 3.
6. Secure the conduit box mounting flanges, preferably to the same mounting surface used for the inverter.
7. Route the AC and DC wire thru the appropriate knockouts/strain reliefs on the conduit box and connect the AC and DC wiring per the inverter's installation procedure.
8. After ensuring all electrical and hardware connections are correct and secure, attach the cover of the conduit box to the bottom of the conduit box using the two screws removed in step 1.
9. Apply power to the inverter and test for proper operation.

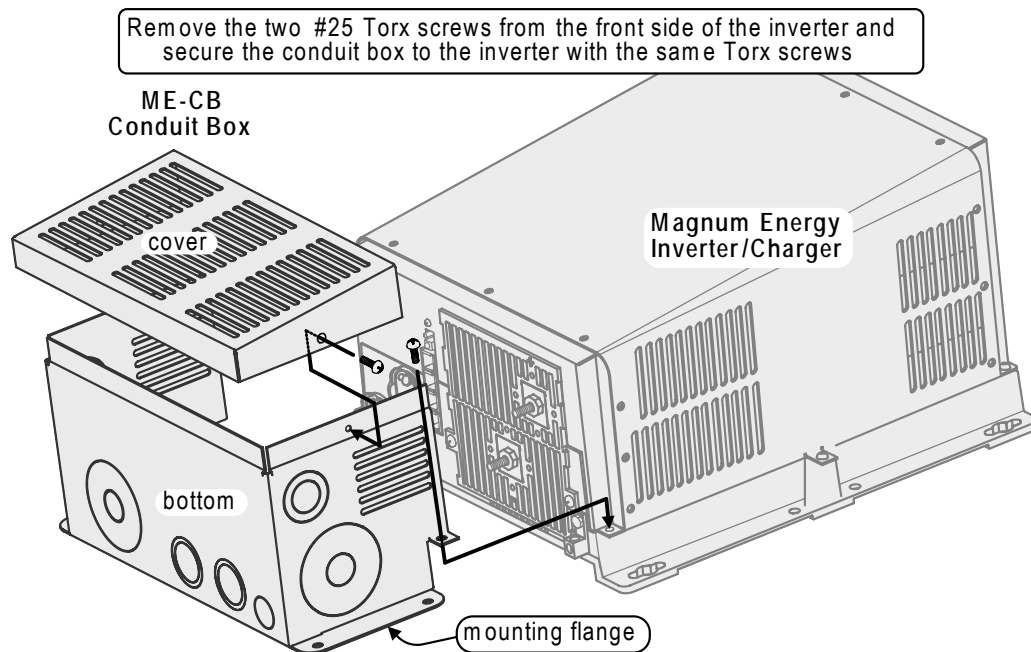

**Figure 3, ME-CB Installation**

## Warranty and Service

### Limited Warranty

Magnum Energy, Inc., warrants the ME-CB conduit box for a maximum of 12 months from the product's original date of purchase; according to the following terms and conditions:

1. The limited warranty extends to the original purchaser of the product and is not assignable or transferable to any subsequent purchaser.
3. During the limited warranty period, Magnum Energy will repair, or replace at Magnum Energy's option, any defective parts, or any parts that will not properly operate for their intended use with factory new or rebuilt replacement items if such repair or replacement is needed because of product malfunction or failure during normal usage. The limited warranty does not cover defects in appearance, cosmetic, decorative or structural parts or any non-operative parts. Magnum Energy's limit of liability under the limited warranty shall be the actual cash value of the product at the time the original purchaser returns the product for repair, determined by the price paid by the original purchaser. Magnum Energy shall not be liable for any other losses or damages.
4. Upon request from Magnum Energy, the original purchaser must prove the product's original date of purchase by a dated bill of sale, itemized receipt.
5. The original purchaser shall return the product prepaid to Magnum Energy in Everett, WA. After the completion of service under this limited warranty, Magnum Energy will return the product prepaid to the original purchaser via a Magnum-selected non-expedited surface freight within the contiguous United States and Canada; this excludes Alaska and Hawaii.
6. This limited warranty is voided if:
  - the product has been modified without authorization,
  - the product has been damaged through abuse, neglect, accident, or corrosion.
  - the product was not installed according to this Installation Guide.

### How to Receive Repair Service

If your product requires warranty service or repair, contact either:

1. An Authorized Service Center listed on the Magnum Energy website at [www.magnumenergy.com/servicecenters.htm](http://www.magnumenergy.com/servicecenters.htm); or
2. Magnum Energy, Inc. at:

Telephone: 425-353-8833  
Fax: 425-353-8390  
Email: [warranty@magnumenergy.com](mailto:warranty@magnumenergy.com)

If returning the product directly to Magnum Energy for repair, you must:

- Return the unit in the original, or equivalent, shipping container.
- Receive a Return Materials Authorization (RMA) number from the factory prior to the return of the product to Magnum Energy.
- Place RMA numbers clearly on the shipping container or on the packing slip.

**BEFORE RETURNING ANY UNIT, CONTACT MAGNUM ENERGY FOR A RETURN MATERIAL AUTHORIZATION (RMA) NUMBER.**